



Translucent Roofing



SEPTEMBER 2010



www.alsynite.co.nz

Alsynite NZ Ltd, a name synonymous with the manufacture and provision of innovative natural lighting roofing products commenced manufacture in New Zealand in 1996.

The company is now an internationally recognised and respected roofing product manufacturer having commissioned a state of the art manufacturing facility in Te Rapa, Hamilton in February 2008.

Fully computerised and automated production lines with advanced forming and cutting equipment, produce high clarity sheeting for New Zealand and International markets.

Alsynite New Zealand continues to design and manufacture cutting edge

Glass fibre-reinforced polyester (GRP) processes and products and is JAZ-ANZ accredited under the Benchmark Certification scheme. Recognised in more than 90 countries and providing security and respect to our customers JAZ-ANZ accreditation not only guarantees accurate systems processes but also ensures consistent and monitored product legally certified to AS 4256.3:2006.

Alsynite NZ Ltd is the New Zealand distributor for Laserlite polycarbonate roofing products manufactured in Australia by Bayer MaterialScience Pty Ltd, and is the New Zealand distributor for CSR Edmonds extensive range of rotary ventilation products. Alsynite also distribute Polygold fibreglass insulation and Polygold Ecomax; 100% polyester

insulation. These products and an extensive range of roofing accessories form a natural adjunct to the translucent sheeting range that ensures Alsynite continues to meet ongoing customer requirements.

Topglass® is also manufactured in Thailand by Topglass FRP International Co Ltd, an Alsynite NZ joint venture company, and is also manufactured in Australia under licence to FGW Corporation Pty Ltd, WA. As identical products are manufactured this ensures customers confidence as Alsynite NZ remains a truly trusted and respected manufacturer and supplier throughout Asia and the Pacific.



THIS LITERATURE SHOULD BE USED IN CONJUNCTION WITH THE ALSYNITE NZ TECHNICAL CATALOGUE.



AS/NZS 4256.3
ID: 2349



BSI 25999



JAZ-ANZ
22560902AS



219760



706441



www.alsynite.co.nz

www.topglass-frp.com

www.fgwcorp.com.au



Projects Using Topglass® Products

Topglass®	NZ Dairies Ltd Factory, Studholme
Topglass®	Wireplus Building, Christchurch
Topglass®	Metro Glass Tech Building, Mt Maunganui
Topglass® Ultra	Bio Extract Plant, Hamilton
Topglass® Ultra Twin Skin	International Sports Velodrome, Invercargill
Topclad™	Kariori Pulp Mill Effluent Treatment Tank
Topclad™	Ravensdown Fertiliser Works

Topglass® GC	Office Max, Auckland
Topglass® GC	Fliway Transport, Auckland
Topglass® SPF 4	Lion Nathan Bottling Plant, Auckland
Topglass® SPF 4	Visy Board factory, Auckland
Topglass® SPF 8	National Mini Storage, Auckland
Topglass® GC	Bunnings Hardware Superstores
Topclad™ Ultra-Safe, Twin Skin	Canterbury Meat Packers (CMP), Ashburton

Contents



For handling, installation and further technical details refer to the Alsynite NZ Technical Catalogue or visit www.alsynite.co.nz

To the best of our knowledge, all information contained herein is correct at the time of printing. It should not be treated as a substitute for detailed information available in the Alsynite NZ Technical Catalogue or website www.alsynite.co.nz

Alsynite NZ Ltd reserve the right to change, modify, or withdraw products from the market, either permanently or temporarily, at any time without notice and without incurring any liability.

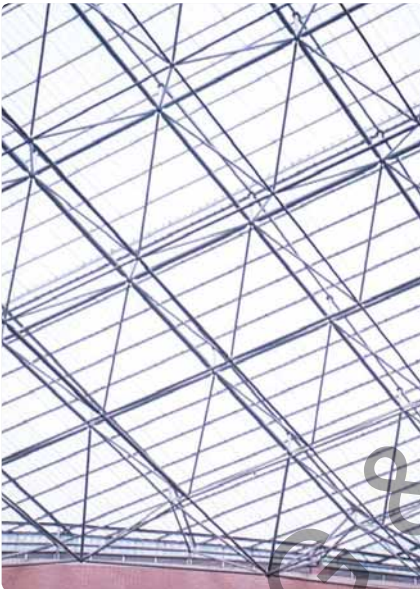
© Alsynite NZ Ltd
® Topglass
® Registered Trademark



 Topglass® UV-Stabilised Commercial Grade Reinforced Translucent Roofing	Page 4
 Topglass® GC Gel-Coated Natural Roof Lighting	Page 6
 Topglass® GC SPF Solar Protective Gel-Coated Natural Roof Lighting	Page 8
 Topglass® GC Ultra-Safe High Impact, Corrosion Resistant Glass Reinforced Roofing and Cladding	Page 10
 Topglass® Ultra High UV Resistant, Commercial Grade Translucent Roofing	Page 12
 Twin-Skin Systems Heat Reducing Translucent Roofing	Page 14
 Triple-Skin Systems Translucent Roofing	Page 16
 Topglass® 50 FR Plus Fire Retardant Translucent Roofing	Page 17
 Topclad™ GC Heavy Duty, Corrosion Resistant, Solid-Coloured Roofing and Cladding System	Page 18
Installation Instructions	Page 20
Project Solutions Chart	Page 22
Technical Information	Page 23



Venting of Fire

Topglass® GRP (Glass fibre reinforced polyester) translucent products are primarily designed as a clear roofing product to allow natural light to enter a building.

Alsynite NZ Ltd, as a response to industry concerns, manufacture an Emergency Ventilation Hatch (EVH) that addresses the potential problems with GRP sheets (not providing ventilation openings in fire situations due to their physical properties).

The EVH has undergone fire and other testing at BRANZ to comply with national and Trans Tasman Standards, and has been BRANZ appraised.

Designed as a specific ventilation system to provide for effective ventilation in the event of a fire, the hatch can be fitted to new construction buildings or retro fitted to roofs of all profiles and most pitches.

Alsynite offer the EVH with a full maintenance and service schedule for peace-of-mind to the end client.

All enquiries contact:
sales@alsynite.co.nz or 0800 257 964
or visit www.alsynite.co.nz



TOPGLASS® COLOUR: OPAL PROFILE: MAXISPAN® 2400 G/M²

Introduction

Topglass® translucent roofing has been specifically developed to combat the effect of ultra violet rays and atmospheric pollutants without the yellowing and rapid product degradation associated with commonly available glass reinforced roof sheeting. Utilising major technological advances developed by both Alsynite NZ and its suppliers, Topglass® is supplied as a cost effective product encompassing a purpose developed UV stabilised composite resin system and surface protected with an Alsynite proprietary weather surface coating providing longer term effective light transmission.

Key Benefits

- Topglass® is manufactured from an acrylic modified resin system, reinforced with high quality glass fibre rovings;
- Topglass® utilises surface coatings which are especially formulated and designed to provide high quality long

term natural light transmission;

- Topglass® encompasses in-built NZA-5 UV inhibitors which prevent early degradation, yellowing and embrittlement of the sheet;
- The product is oven cured and profiled to ensure maximum binding and strength;
- The non-porous weather surface prevents water absorption and osmosis;
- Reduced fibre show in comparison to standard commercial grade translucent roofing products;
- The weather surface retains its smooth finish for a greater period of time providing self cleaning benefits;
- An extremely flexible product providing innovative product variations in meeting design criteria;
- Topglass® is an extremely cost effective UV resistant translucent roof sheeting.
- Closer inspection of Topglass® indicates that only minimal air

bubbles are retained in the composite, resulting in improved aesthetics, extreme clarity and improved strength.

Applications

- Commercial, industrial, institutional and other projects where long-term high quality lighting is required;
- School/Kindergarten and public outdoor areas requiring excellent UV protection.

Special Applications

- Topglass® can be supplied encompassing a purpose developed corrosive resistant resin for use in areas of extreme corrosion.
- All Topglass® products can be supplied in various twin skin systems providing excellent thermal/acoustic benefits and energy savings.
- Topglass® can be supplied tinted to reduce light and heat transmission. (See Table page 5). This is recommended due to the long term clarity of the sheet;
- Topglass® roofing profiles can be supplied in reduced width sheet if so required.

Surface Coatings

The Topglass® weather surface polyester coating incorporates UV inhibitors and offers protection against early yellowing and degradation of the sheet. In specific applications and where minor corrosion may effect the underside of the sheeting, an Alsynite NZ proprietary high sheen corrosion resistant surface can be supplied in place of the standard polyester film.

Colours and Tints

Topglass® is available in standard colours of Clear, Orchid, Opal and Cool. Other colours to suit specific design criteria are available on request. Consult Alsynite NZ Ltd as minimum quantities apply.

Operating Temperature

The operating temperature range of Topglass® is - 40° to +110° C.

Visible Light and Solar Transmission

Weight	Clear		Orchid		Opal		Cool*	
	Light	Solar	Light	Solar	Light	Solar	Light	Solar
1800g/m ² (1.1mm)	84%	75%	78%	69%	70%	52%	n/a	n/a
2400g/m ² (1.5mm)	74%	65%	65%	60%	58%	49%	33%	22%
3660g/m ² (2.5mm)	62%	58%	60%	56%	47%	40%	n/a	n/a

Light and Solar transmission information is issued as a guide only and based on interpretation of natural exposure testing. Full test information is available from Alsynite NZ Ltd. Topglass® Solar, Optical and Ultra Violet Transmission information is contained in the Alsynite NZ Technical Catalogue see www.alsynite.co.nz

*Topglass® cool provides blocking of 99.9% UVA and 100% UVB harmful Ultra Violet Light.

Solar heat gain	227w/m ²
Shading co-efficient	.33
Solar head gain co-efficient	0.20
UVA transmittance	.1%
UVB transmittance	0.0%



Compare the discolouration of sheeting after accelerated weathering

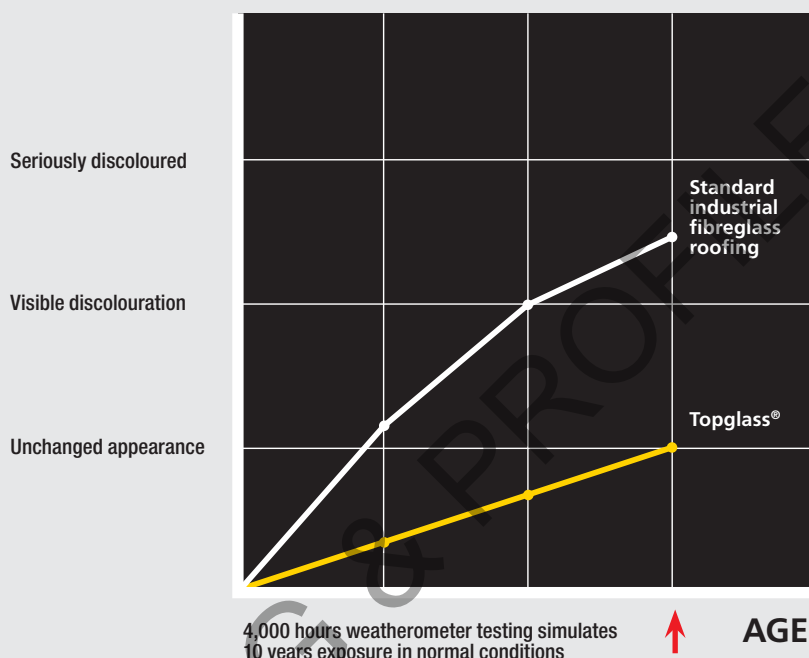

Topglass® out-performs conventional fibreglass materials. Topglass® retains light transmission and discolouration resistance after 4,000 hours continuous UV exposure (equivalent to 10 years in 'normal' conditions).

Specification

The Translucent roofing shall be Topglass® (Insert tint/colour) reinforced polyester roof sheeting as manufactured by Alsynite NZ Ltd to comply with AS 4256.3: 2006 JAS-ANZ Certification Licence No. 2349.

The sheeting shall be measured in g/m² or mm (sheet thickness) and manufactured to conform to the nominated roofing and cladding profile (refer to Technical Information, page 23). Installation shall be carried out in accordance with the requirements of AS 1562.3: 2006, Topglass® technical literature and Alsynite NZ Technical Catalogue.

WARRANTY

Topglass® is supported by a comprehensive 25 year warranty and a 15 year light transmission warranty. For written project warranties, contact Alsynite NZ Ltd.



Fire Retardant

Topglass® can be supplied as fire retardant sheeting. See Topglass® 50 FR Plus Page 17.

Safety

To comply with the requirements of AS 1562.3: 2006 Part 3 Plastic, translucent roofing products are classified as "Brittle Roofing" and therefore not suitable to support foot traffic. With exception of Topglass® CG Ultra-Safe (see page 10.) Safety mesh should be installed under all translucent roofing.

Weathering Performance

Topglass® incorporates UV inhibitors. Extended UV testing shows a significant reduction in UV degradation and yellowing as shown. Topglass® sheeting will have a service life of at least 25 years in normal conditions.

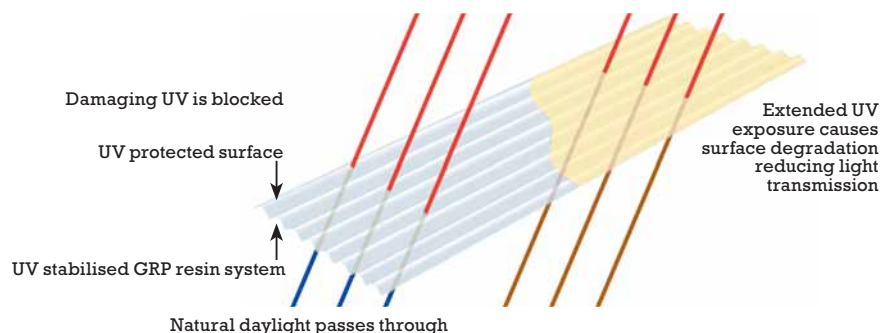



TOP GLASS® GC
COLOUR: OPAL
PROFILE: MULTIRIB™ - 2800 G/M²

Introduction

Topglass® GC is the flagship of the Topglass® natural lighting family of products, and uses an innovative manufacturing process developed by Alsynite NZ, whereby Silmar 100 micron Gelcoat is applied to the weather surface of the sheeting.

Offering exceptional resistance against corrosive atmospheres, and providing protection against solar deterioration, Topglass® GC brings additional benefits to building designers and owners. Topglass® GC can also be supplied in solid colours providing an excellent alternative to metal roofing and cladding systems in corrosive environments. See Topclad page 12.

Key Benefits

- Manufactured from an acrylic modified polyester resin system and incorporating additional ultra violet stabilisers, Topglass® GC utilises antistatic high quality glass fibre rovings to give maximum strength during the curing and bonding process;
- The ultimate benefit of the Topglass® GC product over general purpose grades of GRP natural roof lighting products is the addition of a UV-

stabilised 100 micron** Silmar gel-coated surface which is reactive thermo-set to provide a high gloss surface;

- Topglass® GC, which is manufactured to meet the requirements of AS 4256:3.2006, is economical and provides flexibility whilst resisting UV degradation and yellowing much longer than is commonly experienced with general purpose grade translucent roofing products;
- Harmful Ultra Violet Rays remain a major concern for todays building designers. Topglass® GC can be supplied in a variety of pigments and can be supplied as Topglass® GC SPF. This innovative gelcoat additive provides excellent UVA and UVB block and offers exceptional heat and light data (refer page 8).

and other buildings requiring long term natural lighting without early surface degradation;

- School/Childcare Centres and public outdoor areas requiring good UV protection.

Special Applications

- Topglass® GC can be pigmented to meet varying light and solar transmission requirements;
- Heavy duty solid colour-fast roofing and cladding can be supplied to replace traditional roofing and cladding products for use where corrosion exists. These are manufactured as Topclad GC (refer page 18).

Applications

- Roof and wall lighting to all commercial, industrial, institutional

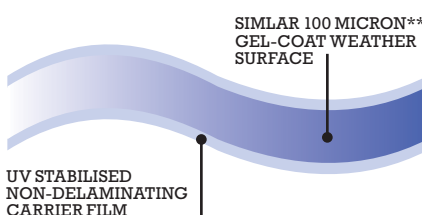

Surface Coatings

The Silmar® 100 micron** gel coat used in the manufacture of Topglass® GC gives very good protection against solar deterioration. The reverse side of the sheeting is protected with a 20 micron UV stabilised Polyester film. Where corrosive atmospheres exist which affect the underside of the sheeting, Alsynite NZ Proprietary highsheen corrosive resistant surface can be supplied in place of the film.

** Nominal 100 micron Gelcoat



Colours and Tints

Topglass® GC is available in standard colours of Clear, Orchid, Opal and Cool. Other colours to suit specific design criteria are available on request. Consult Alsynite NZ Ltd as minimum quantities apply.

Noise Reducing Sheeting

Topglass® GC can be supplied as an effective noise reducing sheeting. See: Topglass® Twin Skin Systems and Triple Skin Systems (pages 14 and 16).

Operating Temperature

The operating temperature of Topglass® GC is -30°C to + 70°C.

Fire Retardant

Topglass® GC can be supplied as fire retardant sheeting. See Topglass® 50 FR Plus Page 17.

Safety

To comply with the requirements of AS 1562.3: 2006 Part 3 Plastic, translucent roofing products are classified as "Brittle Roofing" and therefore not

Visible Light and Solar Transmission

Weight	Clear		Orchid		Opal		Cool	
	Light	Solar	Light	Solar	Light	Solar	Light	Solar
1800g/m ² (1.1mm)	84%	75%	78%	69%	70%	52%	n/a	n/a
2400g/m ² (1.5mm)	74%	65%	65%	60%	58%	49%	33%	22%
3660g/m ² (2.5mm)	62%	58%	60%	56%	47%	40%	n/a	n/a

Light and Solar transmission information is issued as a guide only and based on interpretation of natural exposure testing. Full test information is available from Alsynite NZ Ltd. Topglass® Solar, Optical and Ultra Violet Transmission information is contained in the Alsynite NZ Technical Catalogue see www.alsynite.co.nz

suitable to support foot traffic. With exception of Topglass® GC Ultra-Safe (see page 10.) Safety mesh should be installed under all translucent roofing.

Severe Corrosion Environments

In areas where corrosion is severe Topglass® GC can be manufactured using a special purpose Vinyl Ester corrosion-resistant resin system.

Specification

The Translucent roofing shall be Topglass® GC (Insert tint/colour) reinforced Polyester roof sheeting as manufactured by Alsynite NZ Ltd to comply with AS 4256.3: 2006 JAS-ANZ Certification Licence No. 2349.

The sheeting shall be measured in g/m² or mm (sheet thickness) and manufactured to conform to the nominated roofing and cladding profile (refer to Technical Information, page 23). Installation shall be carried out in accordance with the requirements of AS 1562.3: 2006, Topglass® technical literature and Alsynite NZ Technical Catalogue.

WARRANTY

Topglass® GC is supported by a comprehensive 25 year warranty and a 20 year visible light and solar transmission warranty. For written project warranties, contact Alsynite NZ Ltd.



Topglass GC SPF

Solar Protective Gel-coated Natural Roof Lighting



TOPGLASS® GC SPF 4, MULTIRIB™ - 2400 G/M²

Introduction

A revolutionary and innovative Gel-Coated natural lighting product developed using Alsynite NZ Technology and aptly named Topglass SPF - Solar Protection Feature. Encompassing a unique manufacturing process similar to that used in the design and manufacture of modern sunglass eyewear, Topglass® SPF Solar control roof lighting, selects and singles out Infra-Red (heat) plus harmful Ultraviolet rays, thereby preventing heat build-up and UV damage to Stock and Plant.

Key Benefits

- Provides maximum visible light transmission whilst preventing unwanted solar transmission into a building.
- Reduces energy and air-conditioning costs along with the need for additional artificial lighting.
- Virtually eliminates harmful UVA and UVB ultra violet rays from entering a building.
- The sheet is aesthetically unique, providing innovative design characteristics for building designers.
- Long term effective light transmission.

- Excellent project warranties.
- Topglass® SPF is JAS-ANZ certified to AS 4256:3.2006 Licence No. 2349.

Applications

- Food manufacturing buildings;
- Warehouses and retail outlets storing food and fresh produce;
- Shopping centres and supermarkets;
- Bulk paper stores;
- Temperature-sensitive environments requiring high quality long-term natural lighting.

Product Variations

Product	Visible Light Transmission	Total Solar Transmission
Topglass SPF 4	64%	50%
Topglass SPF 8	49%	36%

Weather surface coating

Silmar® 100 micron* gel-coated weather surface.

* Nominal 100 micron

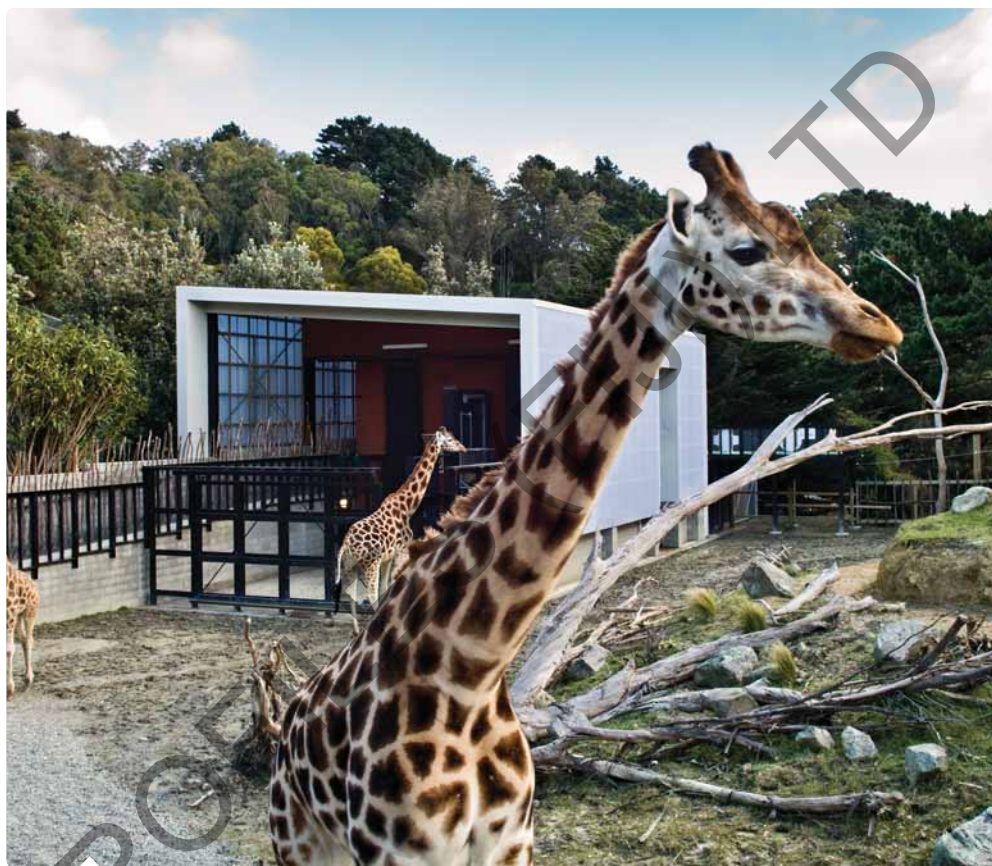

WELLINGTON ZOO - GIRAFFE ENCLOSURE

Operating temperature

The operating temperature of Topglass® SPF is -30°C to +70°C.

Safety

To comply with the requirements of AS 1562.3: 2006 Part 3 Plastic, translucent roofing products are classified as “Brittle Roofing” and therefore not suitable to support foot traffic. With the exception of Topglass® GC Ultra-Safe (see page 10.) Safety mesh should be installed under all translucent roofing.

Roof profiles

Topglass® SPF 4 and Topglass® SPF 8 are manufactured to match all commonly available roofing and cladding profiles, including flat sheet.

Severe corrosive environments

In areas where corrosion is severe, Topglass® SPF can be manufactured incorporating special purpose Vinyl-Ester Resin. Where internal corrosion exists such as indoor swimming pools, a proprietary corrosion resistant and high polished reverse side surface can be supplied.

Weight/thickness of sheeting

Topglass® SPF Products are manufactured in varying sheet thickness as follows: Roof profiles: 1800g/m² (1.1mm) to 3660g/m² (2.5mm) Flat sheet: 1800g/m² (1.1mm) – 4000g/m² (2.7mm)

Specification

The translucent roofing shall be Topglass® SPF 4 - SPF 8 (delete one) gel-coated natural roof lighting system, JAS-ANZ Certified and as manufactured by Alsynite NZ Ltd to comply with AS 4256:3.2006, Licence No. 2349. The sheeting shall be measured in g/m² or mm (sheet

thickness) and manufactured to conform to the nominated roofing and cladding profile (refer to Technical Information, page 23). Installation shall be carried out in accordance with the requirements of AS 1562.3: 2006, Topglass® technical literature and Alsynite NZ Technical Catalogue.

Test Reports

Full Vipac test reports are available on Topglass® GC SPF 4 and SPF 8 for Single-Skin and Twin-Skin System applications. Measurement and Calculation of Twin Skin Solar Optical Properties, 6 March 2008. Vipac Engineers and Scientists Ltd, Melbourne Vic. This information is available on request.

WARRANTY

Topglass® SPF is supported by a comprehensive 25 year warranty and a 20 year light transmission warranty. For written project warranties, contact Alsynite NZ Ltd.



Topglass GC Ultra-Safe

High Impact, Corrosion Resistant Glass Reinforced Roofing and Cladding



WELLINGTON ZOO AMPHITHEATRE

Introduction

Industry concerns relating to Natural Roof-Lighting being classified as “brittle” and therefore possibly posing a danger to foot traffic on the roof, has led to Alsynite NZ purpose develop a heavy duty and high impact roof lighting system to alleviate these concerns. Aptly named Topglass® GC Ultra-Safe, the product utilises a heavy duty, woven roving reinforcing system positioned within the resin matrix, thereby providing exceptional strength. Further, the innovative fastening system jointly developed by Alsynite NZ Ltd and the Company’s fastening supplier provides maximum security to any foot traffic across the roof once installed whether this is day, night or in times of restricted visibility.

Key Benefits

- Topglass® GC Ultra-Safe is manufactured utilising heavy duty woven roving enclosed within the resin matrix which in turn provides a structural capability not normally available with traditional translucent roofing materials.

- Topglass® GC Ultra-Safe meets the impact strength tests of AS/NZS 4040 and satisfies the requirements of AS 4256.3 alleviating the need for safety mesh to be installed under the sheeting (refer to Safety) This is of particular benefit to building designers who face corrosive atmospheres damaging the safety mesh zinc coating.
- As the roving matrix runs both longitudinally and laterally within the sheet, Topglass® GC Ultra-Safe demonstrates exceptional high impact strength.
- A 100 micron Silmar Gel coated surface provides long term light transmission and is supported by a 20 year weather surface structured warranty.
- Corrosion resistant when installed in wide range of aggressive environments.
- Excellent spanning capabilities.
- Topglass® GC Ultra-Safe meets the impact strength tests of AS 4256.3 clause 11.3, AS 4040, and AS 1562 alleviating the need for safety

mesh, rather than just a roof lighting product.

Applications

- Educational facilities and Public Assembly areas where there is a danger of persons climbing onto a roof.
- Fertiliser Plants
- Chemical and Powder-coating Plants
- Wool scouring facilities
- Waste water treatment plants
- Salt Extraction Facilities
- Severe marine environments
- Natural roof lighting where safety mesh is not installed
- Wood Pulp and Paper Plants

Special Applications

- In very severe corrosive environments the Topglass® GC Ultra-Safe resin system can be fortified using Vinyl Ester to provide maximum protection.



WELLINGTON ZOO AMPHITHEATRE

- Topglass® GC Ultra-Safe can be supplied as a heavy duty solid coloured roofing and cladding material to replace metal roofing products for use in corrosive environments. See also Topclad™ GC Page 18.

Weight Thickness of sheeting

Topglass® GC Ultra-Safe is supplied as standard weight of 3660g/m².

Colours

The standard colours of Topglass® GC Ultra-Safe are translucent Clear and Opal. Other pigments are available subject to minimum order quantity.

Profiles

Topglass® GC Ultra-Safe is available to match most common roofing profiles.

Light and Solar Transmission

Tint	Visible Light Transmission	Solar Transmission
Clear	61%	56%
Opal	58%	49%

Spanning

Refer Load Span Capabilities: Technical Information page 23.

Safety

Whilst Topglass® GC Ultra-Safe is classified as heavy duty, meets the impact test of AS 4040, satisfying the requirements of AS 4256.3, and can support foot traffic, long term degradation and or post roof installation impact damage can seriously affect the performance of the sheeting. In order to comply with the requirements of AS 1562.3:2006 Part 3 Plastic, protect the weather surface coating and provide continual structural strength, all FRP products should be protected from foot traffic, therefore a suitable proprietary aluminium walkway is always recommended. Consult Alsynite NZ Ltd for recommended systems.

Specification

The translucent sheeting and/or roofing and cladding shall be Topglass® GC Ultra-Safe (insert tint) as manufactured by Alsynite NZ Ltd to comply with AS 4256.3 JAS-ANZ Certification Licence No 2349. The sheeting shall conform to the nominated roofing and cladding profile and installed in accordance with the requirements of the Alsynite Topglass® GC Ultra-Safe proprietary safety fixing system.

WARRANTY

Topglass® GC Ultra-Safe is supported with a 20 Year weather surface structured warranty and a 10 year structured loss of light transmission warranty. Full warranty conditions and written project warranties are available from Alsynite NZ.



Topglass Ultra

High UV Resistant, Commercial Grade Translucent Roofing



Introduction

Topglass® Ultra has a heavy duty UV resistant surface layer offering improved long term weathering performance and light transmission without experiencing early product yellowing and surface degradation as has been evident in the past.

Key Benefits

- Topglass® Ultra is manufactured from a new generation composite resin system incorporating a highly UV-stabilised inhibitor known as NZA-5 exclusive to Alsynite NZ, which is then mixed with quality glass roving materials;
- After in-house batching of the resin providing uniformity and excellent clarity, all roofing profiles, flat sheet and accessories, are manufactured in a continuous ultra modern and computerised production line process, achieving maximum bonding and curing of the substrate;
- The extra heavy duty non-porous weather surface prevents water absorption and osmosis;
- Reduced fibre show in comparison to standard commercial grade translucent roofing products;
- Topglass® Ultra encompasses in-built UV inhibitors which prevent early degradation, yellowing and embrittlement of the sheet;

- An extremely flexible product in meeting most design criteria requirements;
- A new generation composite matrix incorporating high quality anti-static glass fibre rovings;
- UV-stabilised non-delaminating weather surface technology;
- UV-stabilised non-delaminating carrier film;
- Transmission of harmful Ultra Violet Rays remain a major concern for today's building designers.

UV STABILISED EXTRA HEAVY DUTY NON-DELAMINATING WEATHER SURFACE TECHNOLOGY

"UV GUARD" NEW GENERATION COMPOSITE UV STABILISED RESIN SYSTEM INCORPORATING HIGH QUALITY ANTI-STATIC GLASS FIBRE ROVINGS

UV STABILISED NON-DELAMINATING CARRIER FILM

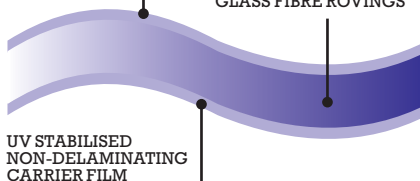

Applications

- Roof and wall lighting to all commercial, industrial, institutional and other buildings requiring long term high quality lighting;
- School/Childcare Centres and public outdoor areas requiring excellent UV protection;

- Buildings requiring specific light and heat transmission requirements.

Special Applications

Topglass® Ultra can be supplied encompassing a purpose developed resin system for use where extreme corrosion atmospheres are present.

Surface Coatings

The heavy duty UV-stabilised weather surface coating used in the manufacture of Topglass® Ultra offers excellent protection against water absorption, solar deterioration and surface embrittlement. In specific applications and where minor corrosion may effect the underside of the sheeting, an Alsynite NZ proprietary high sheen corrosion resistant surface can be supplied in place of the standard polyester film.

Colours and Tints

Topglass® Ultra is available in standard colours of Clear, Orchid, Opal and Cool. (See table page 13). Other colours to suit specific design criteria are available on request. Consult Alsynite NZ Ltd as minimum quantities apply.

Operating Temperature

The operating temperature range of Topglass® Ultra is -40°C to +110°C.

Fire Retardant

Topglass® Ultra can be supplied as fire retardant sheeting. See Topglass 50 FR Plus Page 17.

Safety

To comply with the requirements of AS 1562.3: 2006 Part 3 Plastic, translucent roofing products are classified as “Brittle Roofing” and therefore not suitable to support foot traffic. With exception of Topglass® GC Ultra-Safe (see page 10.) Safety mesh should be installed under all translucent roofing.

Weathering Performance

The weather surface coating and the resin core of Topglass® Ultra incorporate additional UV inhibitors. University testing shows a significant reduction in UV discolouration. Topglass® Ultra sheeting will have a service life of at least 25 years in normal conditions.

Specification

The translucent roofing shall be Topglass® Ultra (Insert tint/colour) reinforced polyester roof sheeting as manufactured by Alsynite NZ Ltd to comply with AS 4256.3: 2006 JAS-ANZ Certification Licence No. 2349.

The sheeting shall be measured in g/m² or mm (sheet thickness) and manufactured to conform to the nominated roofing and cladding profile. Installation shall be carried out in accordance with the requirements of AS 1562.3: 2006, Topglass® technical literature and Alsynite NZ Technical Catalogue.

Visible Light and Solar Transmission

Weight	Clear		Orchid		Opal		Cool	
	Light	Solar	Light	Solar	Light	Solar	Light	Solar
1800g/m ² (1.1mm)	84%	75%	78%	69%	70%	52%	n/a	n/a
2400g/m ² (1.5mm)	74%	65%	65%	60%	58%	49%	33%	22%
3660g/m ² (2.5mm)	62%	58%	60%	56%	47%	40%	n/a	n/a

Light and Solar transmission information is issued as a guide only and based on interpretation of natural exposure testing. Full test information is available from Alsynite NZ Ltd. Topglass® Solar, Optical and Ultra Violet Transmission information is contained in the Alsynite NZ Technical Catalogue see www.alsynite.co.nz

Compare the yellowness of sheeting after accelerated weathering

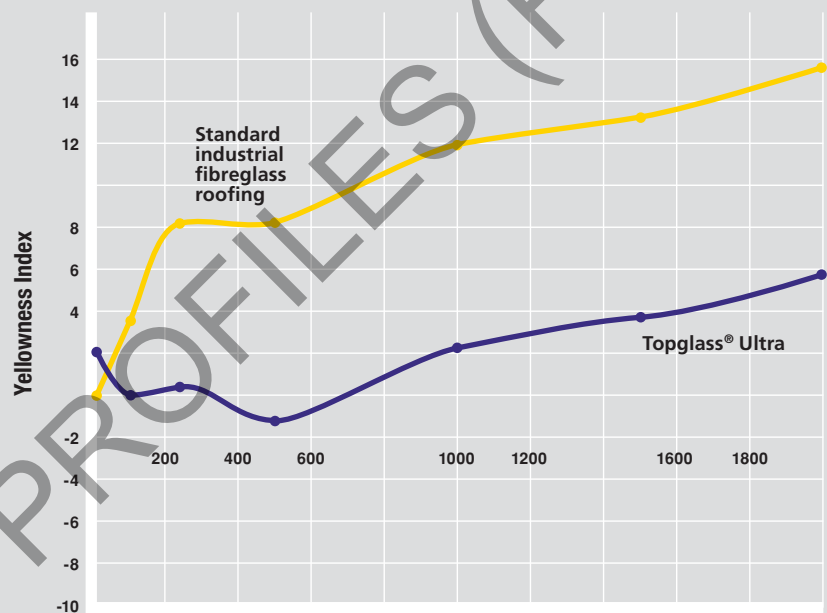

2,000 hours weatherometer testing simulates 5 years exposure in normal conditions



TOPGLASS® ULTRA

WARRANTY

Topglass® Ultra is supported by a comprehensive 25 year warranty and a 20 year light transmission warranty. For written project warranties, contact Alsynite NZ Ltd.



Twin Skin Systems

Heat Reducing Translucent Roofing



TWIN SKIN SYSTEMS

Introduction

Where potential condensation issues are of concern Alsynite manufacture a Twin Skin System that offers a solution to this problem.

Two independently formed sheets of Topglass® are laid over each other to form an effective air gap between the sheets. Condensation evaporates and this prevents water droplets entering the building. Alsynite Twin Skin Systems also offers building occupants a reduced noise level from outside influences, as the system offers an effective acoustical reducing solution.

Key Benefits

- Manufactured from an acrylic modified resin system, reinforced with high quality glass fibre rovings.
- Reduces internal heat buildup and offers a passive natural lighting concept.
- Effective noise reducing system.
- Eliminates condensation in most applications.
- Manufactured and supplied to side-lap most current popular steel

roofing profiles.

- Manufactured and supplied in one length as a complete system, ridge-to-gutter or ridge-to-step if a stepped roof.

Applications

Commercial, industrial, institutional sports stadiums and other projects where long term high quality natural lighting is required.

Special Applications

Alsynite's Twin Skin System can be supplied to meet varying light and solar transmission requirements to meet any design criteria.

Surface Coatings

Topglass® GC is the preferred choice for Twin Skin Systems for the external weather surface. Gelcoat offers very good protection against solar deterioration. A 20 micron film can be applied to the reverse side of the laminate or where corrosive

atmospheres exist which may affect the underside of the sheeting. Alsynite proprietary high level corrosive resistant protective sheen can be supplied.

Colours and Tints

Alsynite Twin Skin Systems typically are supplied with a low pigment additive in the top sheet (Orchid) and a clear support under sheet.

This configuration offers the building interior a soft passive environment without direct sunlight penetration. However any combination of pigment colours are readily available, consult Alsynite for pigment level recommendations.

Heat Reducing Sheeting

As an added barrier against solar heat buildup Twin Skin Systems can include SPF 4 and SPF 8 formulations.

Operating Temperature

Alsynite Twin Skin Systems operating temperature is -30°C to +70°C



TWIN SKIN SYSTEMS

TWIN SKIN SYSTEM

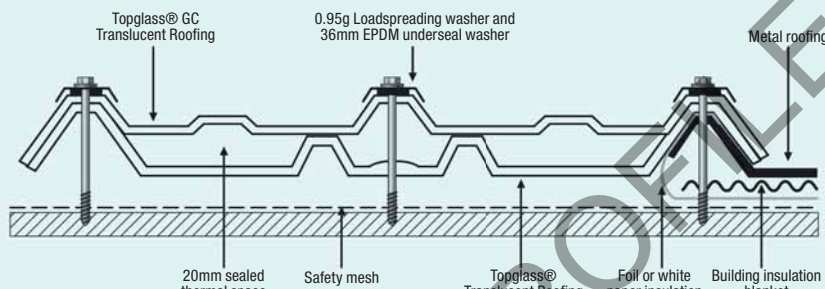

NOTE:
 • Gutter end sealed with purpose made Alsynite closed cell foam strip
 • Twinskin clear roofing at 2400g/m² (1.5mm thick) provides light transmission of 70%

Fire Retardant

Alsynite Twin Skin Systems can be supplied as Topglass® 50FR Plus (refer to page 17).

Safety

To comply with the requirements of AS 1562.3:2006 Part 3 Plastic, translucent roofing products are classified as brittle roofing and therefore not suitable to support foot traffic – with the exception of Topglass® GC Ultra-safe (refer to page 10). Note that safety mesh should be installed under all translucent roofing.

Severe Corrosion Enviroments

In areas where corrosion is severe Twin Skin Systems can be supplied with a vinyl ester resin system.

Specification

The translucent Twin Skin System shall be Alsynite reinforced polyester roof

sheeting manufactured by Alsynite to comply with AS4256.3:2006 JAZ-ANZ certification licence number 2349. The sheeting shall be measured in g/m² or mm (sheet thickness) and manufactured to conform to the nominated roofing and cladding profile (refer to Technical Information, page 23).

Installation shall be carried out in accordance with the requirements of AS 1562.3:2006 Topglass® technical literature and the Alsynite NZ technical catalogue.

Test Reports

Test reports have been carried out on Twin Skin products for testing their acoustical and solar optical properties as listed below:

1. Laboratory Measurement of Air-bourne Sound Insulation of TS20 Twin Skin Roofing System, Auckland UniServices Limited, 3 December 2008. According to ISO 140-3.
2. Measurement and Calculation of TS20 Solar Optical Properties, Vipac Engineers & Scientists Ltd, Melbourne, VIC, 6 March 2008.
3. Measurement and Calculation of Twin Skin Solar Optical Properties, Vipac Engineers & Scientists Ltd, Melbourne, VIC, 20 June 2007.

This information is available upon request.

AWTA Textile Testing:

Test report No. 7-573904-NO to AS/NZS 4859.1
 A copy of the test report is available upon request from Alsynite NZ.

WARRANTY



Alsynite Twin Skin Systems are supported by a comprehensive 25 year warranty and a 20 year light transmission warranty. For written project warranties contact Alsynite NZ Ltd.

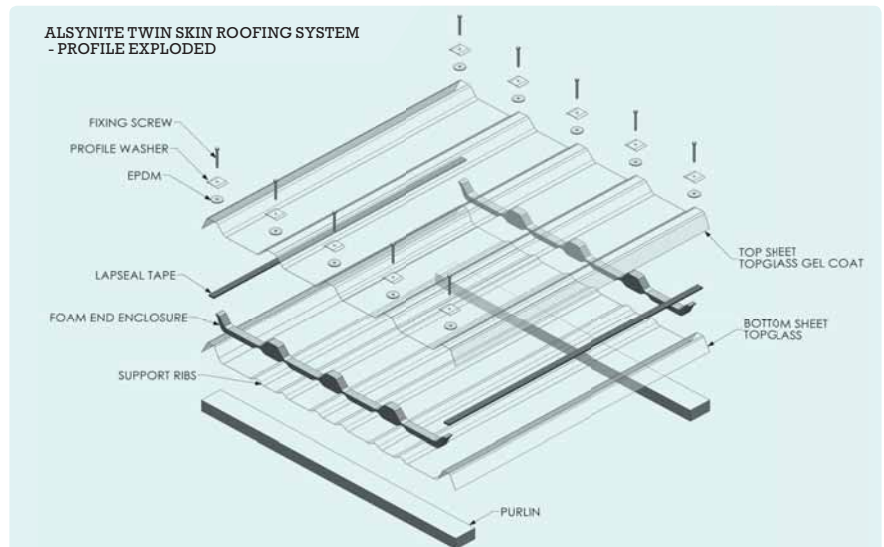

Triple Skin Systems

Translucent Roofing

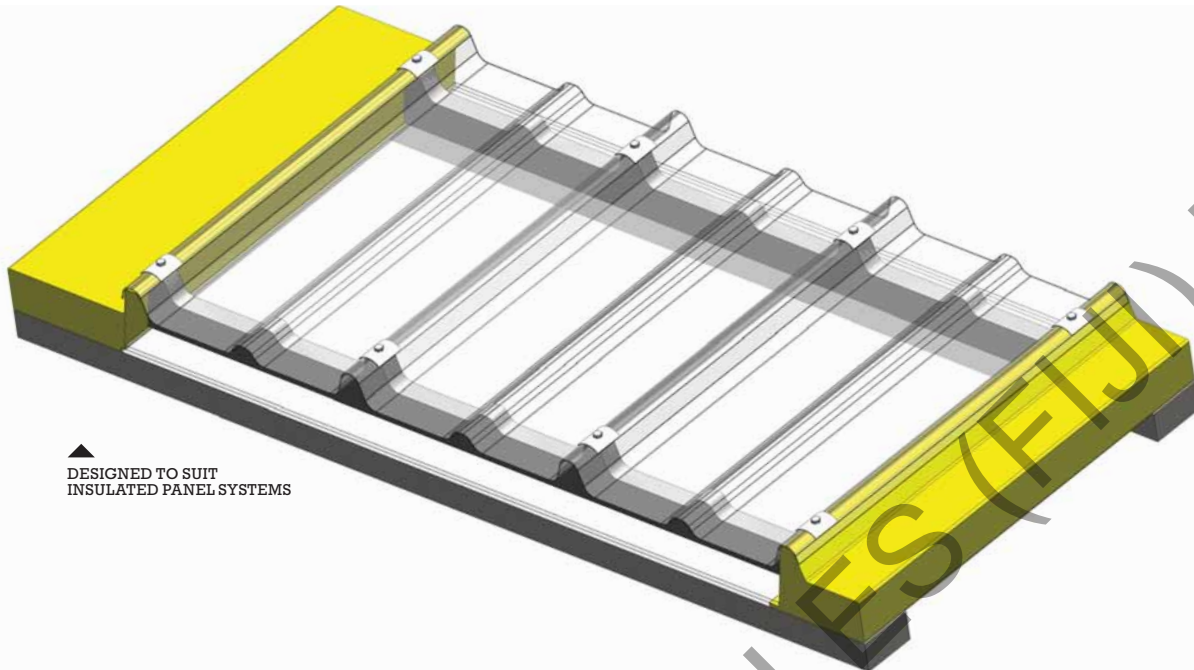

DESIGNED TO SUIT
INSULATED PANEL SYSTEMS

Introduction

Topglass® Triple-Skin Systems are primarily designed as a suitable fully insulated natural lighting roofing product.

Topglass® GC Ultra-Safe is utilised as a weather surface sheet and two flat sheets of 6mm Laserlite Makrolon Multiwall form the bottom layers. Offering increased thermal and acoustical properties these systems are utilised in conjunction with insulated panel products.

Key Benefits

- Manufactured from an acrylic modified resin system reinforced with high quality glass rovings, with the incorporation of a reinforced woven roving matrix and Laserlite Makrolon Multiwall.
- Increased thermal resistance and increased acoustical properties.
- Eliminates condensation in most applications.
- Manufactured and supplied to match insulated panel systems.

Applications

Compliments commercial buildings that require insulated roofing panel construction, and provides natural lighting with the added benefit of offering good thermal resistance.

Surface coatings

Topglass® GC is the preferred choice for Triple-Skin Systems for the external weather surface. Gelcoat offers very good protection from solar deterioration. Triple-Skin Systems can be supplied in most weights g/m² but Topglass® GC Ultra-Safe is recommended for this system.

Colours and Tints

Triple-Skin Systems can be supplied in a variety of tints but generally is supplied as translucent clear.

Operating Temperature

Triple-Skin Systems operating temperature is -30 c to + 70 c

Safety

Topglass® Triple-Skin Systems supplied as Topglass® GC Ultrasafe is classified as heavy duty, meets the impact test of AS 4040, satisfying the requirements of AS 4256.3 and can support foot traffic, long term degradation and or post roof installation impact damage can seriously affect the performance of the sheeting.

In order to comply with the requirements of AS 1562.3 2006 part 3 plastic, protect the weather surface coating and provide continual structural strength, all GRP products

should be protected from foot traffic, therefore a suitable proprietary aluminium walkway is always recommended.

Consult Alsynite NZ Ltd for recommended systems.

Specification

The translucent sheeting shall be Topglass® GC Ultrasafe, Triple-Skin System 3660 g/m² (unless specified otherwise) manufactured to comply with AS 4256.3 JAZ-ANZ certification licence no. 2349.

The sheeting shall conform with the nominated roofing and cladding profile and be installed in accordance with the requirements of the Alsynite Topglass® Ultrasafe proprietary safety fixing system. Refer Page 10 - Key Benefits (Topglass® GC Ultra-Safe).

AWTA Textile Testing:

Test report No. 7-572999-NO to AS/NZS 4859.1

A copy of the test report is available upon request from Alsynite NZ.

WARRANTY

Topglass® GC Ultra-Safe, Triple-Skin Systems are supported with a 25 year weather surface warranty and a 20 year structured loss of light transmission warranty. Full warranty conditions and written project warranties are available from Alsynite NZ.



10 Clone Calorimeter testing to AS/NZS 3837: 1998

Topglass 50 FR Plus

Fire Retardant Translucent Roofing



TOP GLASS® 50 FR PLUS, PROFILE: MULTISPAN

Introduction

Topglass® 50 FR Plus is designed and supplied as a fire and smoke retardant natural lighting system for use in commercial and industrial buildings. This type of resin system alters the flammability point of the sheeting, however it should be noted Alsynite supplies all GRP sheeting in this brochure as natural lighting/cladding products only.

Please refer Page 3 Venting of Fire, for alternative mechanical smoke and heat venting systems.

Key Benefits

- Topglass® 50 FR Plus is a glass reinforced polyester fire retardant sheeting that has been specifically formulated using fire retardant materials for use in commercial building applications and educational institutions.
- Topglass® 50 FR Plus is a glass reinforced polyester fire retardant sheeting that can be considered into building designs that specifically require reduced ignitability, flame

propagation and heat and smoke release over conventional resin systems.

Applications

- Schools and educational institutions;
- Public assembly areas;
- Combustible areas with high fire risk;
- Where egress from a building in the event of fire may be restrictive.

Special Applications

AWTA Test Report Number 7-550697-CO to AS/NZS3837 contained in this literature refers to Topglass® 50 FR Plus. Contact Alsynite NZ Ltd for advice on more advanced fire and smoke retardant resin systems.

Surface Coatings

Topglass® 50 FR Plus is supplied with a superior weather surface coating containing inbuilt UV inhibitors offering improved serviceable life. In specific applications and where minor corrosion may affect the underside of the

sheeting, an Alsynite NZ Proprietary high sheen corrosion resistant surface can be supplied in place of standard polyester film.

Colours

The standard colour of Topglass® 50 FR Plus is yellow/clear. Opal pigment can be incorporated where specific heat and light transmission is required.

Safety

To comply with the requirements of AS 1562.3: 2006 Part 3 Plastic, translucent roofing products are classified as "Brittle Roofing" and therefore not suitable to support foot traffic. With exception of Topglass® GC Ultra-Safe (see page 10). Safety mesh should be installed under all translucent roofing.

Specification

The Translucent roofing shall be Topglass® 50 FR Plus (Insert tint/colour/grade) reinforced Polyester roof sheeting as manufactured by Alsynite NZ Ltd to comply with AS 4256.3: 2006 JAS-ANZ Certification Licence No. 2349. The sheeting shall be measured in g/m² or mm (sheet thickness) and manufactured to conform to the nominated roofing and cladding profile (refer to Technical Information, page 23). Installation shall be carried out in accordance with the requirements of AS 1562.3: 2006, Topglass® technical literature and Alsynite NZ Technical Catalogue.

Profiles

Topglass® 50 FR Plus is available ex stock in a limited number of roofing profiles. Contact Alsynite NZ Ltd for further information.

WARRANTY

Topglass® 50 FR Plus is supported by a comprehensive 25 year warranty and a 20 year light transmission warranty. For written project warranties, contact Alsynite NZ Ltd.



Test Reports

AWTA Textile Testing:
Test report No. 7-550697-CO to AS/NZS3837 (Clone Calorimeter) and Test report No 7-487161-CO to AS/NZS 1530.3 (Fire indices) are available from the Alsynite NZ Technical Catalogue.

AWTA Textile Testing: simultaneous determination of ignitability, flame propagation, heat and smoke release to AS/NZS1530.3: 1999 can be viewed in the Alsynite NZ Technical Catalogue.

10 Clone Calorimeter testing to AS/NZS 3837: 1998



ROOFING PROFILE: RT7®

Introduction

In some highly corrosive industrial sites and areas of high salt contamination, high build paint coatings on roofing and cladding substrates such as aluminium and steel may not perform as expected. To address these concerns, Alsynite New Zealand manufactures a unique solid-coloured heavy duty roofing and cladding material utilising advanced GRP technology to formulate a corrosive resistant cladding system for use as an innovative replacement for traditional materials.

Key Benefits

- The surface coatings and substrate used in the manufacture of Topclad™ GC have been designed specifically to withstand corrosive atmospheres. The added benefit provided by Topclad™ GC, is the highly polished corrosive resistant surface on the underside of the sheet.
- Topclad™ GC is solid-coloured to match modern roof colours (Subject to pigment availability) this is

achieved by applying a 100 micron* Silmar coloured gel-coat layer to the GRP sheeting substrate.

- Advanced technology associated with the Alsynite NZ Gel-coat manufacturing process allows different solid colour pigmentation to be applied to each side of the sheet, particularly important where the underside of the sheet is not covered by a membrane;
- Available to match a wide range of roof profiles including flat sheet;
- Lightweight cladding for easy handling and installation;
- Reduces solar heat transmission;
- Manufactured to any length.
- Lower freight costs

Applications

- Wool scouring plants;
- Fertiliser buildings;
- Poultry and animal sheds;
- Acid plants and smelters;

- Galvanising plants;
- Effluent tank cladding;
- Extreme marine environments;
- Buildings in geothermal areas;
- Compost plants;
- Tanneries;
- Abattoirs

Special Applications

Where corrosion may be of concern to the underside of the roofing and cladding system, an Alsynite NZ Proprietary high polished corrosion resistant surface can be applied to the underside of the sheet. At additional cost, Vinyl Ester Resin can be incorporated for maximum protection.

Weight/Thickness of Sheeting

The standard weight for Topclad™ GC is 2800g/m² (1.9mm). Other weights up to 3660g/m² (2.5mm) are available subject to minimum order.

* Nominal 100 micron Silmar Gel-coat



CANTERBURY MEAT PACKERS (CMP)
PRODUCT: TOPCLAD™ GC, ULTRA-SAFE, TWIN-SKIN.



PRODUCT: TOPCLAD™ GC COLOUR: TITANIA
PROFILE: HI FIVE 2800 G/M²

Colours

Topclad™ GC provides excellent opportunity to replicate the colours normally associated with pre-painted metal roofing and cladding products. Topclad™ Standard colour range is, Titania, Grey Friars, Silver, Mist Green, and Sandstone Grey. Other colours to suit specific design criteria are available on request. All Topclad™ GC Products are subject to minimum order quantities.

Operating Temperature

Topclad™ GC will not become brittle with age and will not soften or crack within the designed temperature operating range of -30°C to +70°C.

Fire Retardant

Topclad™ GC can be supplied as fire retardant sheeting. See Topglass 50 FR Plus Page 17.

Moisture

Where Topclad™ GC will be in continuous contact with moisture, Alsynite NZ Ltd Technical department should be contacted prior to ordering.

Safety

To comply with the requirements of AS 1562.3: 2006 Part 3 Plastic, translucent roofing products are classified as "Brittle Roofing" and therefore not suitable to support foot traffic. With exception of Topglass®/Topclad™ GC Ultra-Safe (see page 10.) Safety mesh should be installed under all translucent roofing.

Thermal Expansion

2.2 x 10.5 cm / cm °C
E.g. 7m long sheet with a 40°C temperature change = 2.2 x 10.5 x (10 x 100) x 7 x 40 = 6.16mm per 7m length at 40°C temperature rise.

Chemical Resistance

- Topclad™ GC has no known chemical reaction with any construction materials;
- The sheeting is resistant to solar deterioration and most corrosive atmospheres;
- Unaffected by solvents, including hydrocarbons, and provides excellent resistance to most corrosive acids and alkalis.

Specification

The Translucent roofing shall be Topclad™ GC (Insert tint/colour) reinforced Polyester roof sheeting as manufactured by Alsynite NZ Ltd to comply with AS 4256.3: 2006 JAS-ANZ Certification Licence No. 2349. The sheeting shall be measured in g/m² or mm (sheet thickness) and manufactured to conform to the nominated roofing and cladding profile (refer to Technical Information, page 23). Installation shall be carried out in accordance with the requirements of AS 1562.3: 2006, Topglass® technical literature and Alsynite NZ Technical Catalogue.

Flashings

For flashings information contact Alsynite NZ Ltd.

Product Handling

Care must be taken when handling and installing the product to avoid stress damage and/or scratching of the surface.

WARRANTY

Topclad™ GC is supported by a comprehensive 25 year warranty and a 20 year light transmission warranty. For written project warranties, contact Alsynite NZ Ltd.



Installation Instructions

GRP Sheeting

Product Handling and Storage Instructions for All Products

- Store sheeting in a dry location and protect from possible wind damage prior to installation.
- Sheeting should not be dragged across objects or other products as it may affect the performance and aesthetics of the roof sheet.
- Care should be taken when loading the translucent roofing onto the roof to avoid bending or distortion of the sheet.
- Sheeting that becomes wet in bundles and is required to be stored should be separated and dried prior to storage.

Recommended Installation Guidelines

- Sheeting may be cut using an abrasive disc or fine tooth saw (use protection gloves and approved face mask).
- GRP Translucent roofing is not designed to support foot traffic and unless specifically excluded in AS 1562.3:2006, clause 2.4.3 requires the use of safety mesh under all translucent roof sheeting. Refer to Figure 5.
- Alsynite NZ Purlin barrier strip must be installed between the translucent roof sheeting and the safety mesh at the purlin line. Refer to Figure 5.
- Ensure the purlins are correctly spaced and that they are in line.
- GRP fibreglass roofing should always be installed over the main roof cladding at both lapping edges. Refer to Figure 1.

- Ensure the weight/thickness of the sheet combined with the selected roofing profile will meet the spanning requirements.
Contact Alsynite NZ Ltd for specific design advice or refer Load Span Capability Chart - Page 23.
- Ensure that the correct weathering surface of the sheeting is uppermost as the durability and any warranty is dependent on placing the sheet the correct side up.

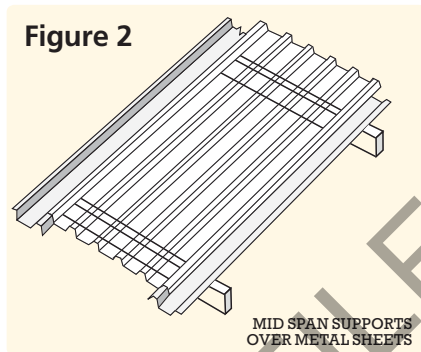

- Where two translucent roof sheets are laid side by side, the mid span support shall extend under the metal roofing sheet by a minimum 400mm with fastening through at least two ribs of the metal roofing on either side of the GRP sheet.
- Mid span supports shall not be used where more than two translucent sheets are adjacent to one another.
- If more than two sheets of Topglass® Roofing products are to be used side by side, contact Alsynite NZ Ltd for specific guidelines.
- Where roof installations require Topglass® or Topclad™ to be laid side-by-side, it is recommended that the use of Lap Seal Tape be implemented in these situations, therefore preventing possible water ingress over the laps.

Stop Ends

Install stop ends to the top of the translucent sheeting as follows.

Method 1

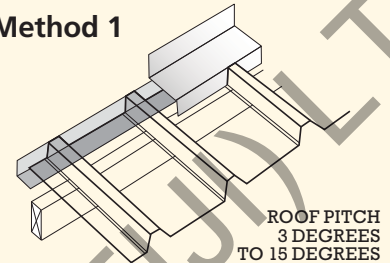

Use a right-angled folded flashing to the full height of the corrugation or rib, fixed with rivets and sealant.

- Severe conditions: Use 0.9mm aluminium.
- Moderate conditions: Use pre-painted metal.

Note: This can also be used in an exposed site or high or very high wind zone for steeper pitched roofs.

Method 2

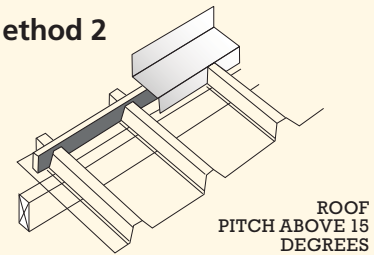

Use Alsynite NZ Ltd approved closed cell profiled foam strip fitted close to the screw fixing points.

Sealants

The use of silicone should be restricted to end laps only as when set the sealant restricts the ability of the sheet to expand and contract. The use of sealants under side laps is not recommended. In some particular building designs i.e. curved roofing and where the pitch may fall below the recommended minimum pitch, Alsynite NZ Ltd Lap seal tape can be applied to lapping edges. Expansion and contraction of dissimilar roofing materials should be taken into prior consideration.

Rainwater Gutters

GRP roof sheeting should not be drained into unpainted or galvanised gutters.

Figure 1

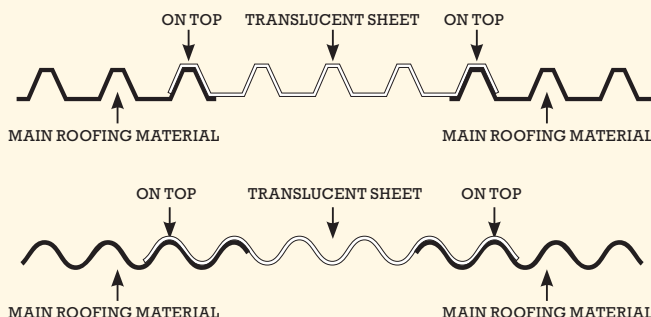



End Laps

- Minimum recommended length of end lap of GRP sheets and/or with metal profile sheeting is 200mm.
- Position of lap over purlin - it is recommended the bottom end of the lap sheet be within 50mm of the lower side of the purlin.
- Position of the seal - the bottom bead should be within 25mm from the bottom of the top sheet in lap, and the top bead of seal within 50mm of the top of the bottom sheet.

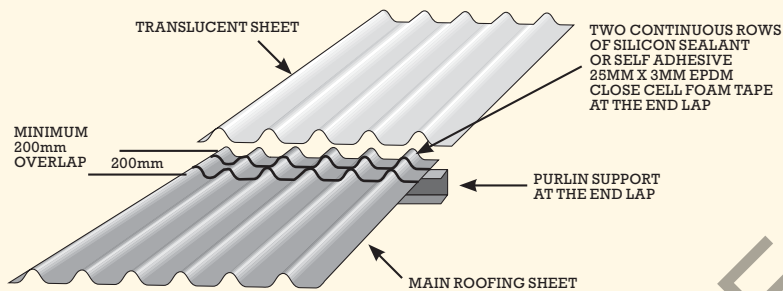

Other fastener methods such as 32mm Weatherlok washers maybe suitable based on sheet length and load characteristics. Alsynite NZ Ltd should be contacted for further clarification and advice.

- All fastener holes should be pre-drilled over-size to accommodate the expansion and contraction of the sheets as follows:

Sheets up to 6m	8mm Ø hole
Sheets 6m to 9m	10mm Ø hole
Sheets 9m to 12m	12mm Ø hole
Sheets 12m to 28m	16mm Ø hole

Note: It is important to centre the fixing in the oversize hole to ensure the sheet has equal movement around the fixing.

Note: Where wind loads exceed 1.5kPa, contact Alsynite NZ Ltd for specific design advice. Do not overdrive the fasteners so that deformation of the sheet occurs.

Side Lap Fixing

Side laps should be fixed at a maximum spacing of 600mm to prevent wind uplift and leakage, and these fixings shall be through the top of the rib.

- When fixing GRP to metal, pre-drill the appropriate oversize hole in the GRP and screw through the centre of the hole into the metal using a self drilling hex head screw 12g or 14g complete with load spreading washer and 36mm EPDM sealing washer. Refer to Figure 3.

Figure 3

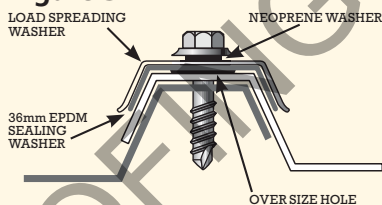

- When fixing GRP to GRP use a bulbrite rivet 6-4w through the top of the rib of the GRP sheets. Refer to Figure 2.

Figure 4

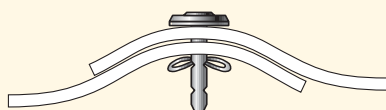

Fastener and Sealing Washer Recommendations

The fastener shall be as for the main roof cladding and will be used in conjunction with a Alsynite NZ Ltd approved load spreading washer constructed of 0.95mm unpainted/prepainted metal or 1.2mm aluminium to match the main cladding material. In a highly corrosive environment, consideration should be given to the use of stainless steel or other appropriate corrosive resistant material.

Inserted under the load spreading washer will be a 36mm EPDM sealing washer which is to be correctly seated to provide an effective seal. Fasteners should be inserted through the top centre of the rib/corrugation.

Figure 5

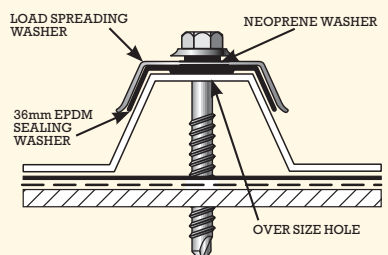

— 5mm ALSYNITE PURLIN BARRIER STRIP (PBS)
 - - SAFETY MESH
 ▨ PURLIN

Fastener Pattern

- Corrugated profile end supports and end laps: Fix side laps and every 2nd corrugation.
- Corrugated profile internal supports or purlins: Fix side laps and every 3rd corrugation.
- 5 rib low trapezoidal profiles (19mm to 30mm): On all purlins fix every rib.
- High trapezoidal profiles (50mm to 120mm): On all purlins fix every rib.
- 7 to 8 rib medium trapezoidal profiles (33mm to 49mm) end support and end laps: Fix every rib.
- 7 to 8 rib medium trapezoidal profiles (33mm to 49mm) internal support or purlins: Fix side laps and every 2nd rib.
- Deck profiles - fix every rib.

Further Technical Assistance

The installation instructions are a guide to assist with installation of translucent roof sheeting. However these should be read in conjunction with the full technical information contained in the Alsynite NZ Technical Catalogue. For non-standard building design such as draped curve roofs, contact Alsynite NZ Ltd for technical advice prior to ordering product or commencing the project.

NOTE: GRP - Glass Fibre Reinforced Polyester



Project Solutions

 Project Solutions	Sequelite	Topglass®	Topglass® Ultra	Topglass® GC SPF	Topglass® 50 FR Plus	Twin Skin System	Topclad™ GC	Topglass® GC	Topglass®/Topclad™ Ultra-Safe	LASERLITE® Polycarbonate			
										Laszfire 2000+, 3000	Solarluff	Maxi-span Maxirevail	Flashings
Competitive priced translucent roof sheet for domestic and commercial use	•	•									•		
Best value translucent roof sheet with UV stabilised surface		•	•						•		•		
Long term light transmitting, UV stabilised surface		•	•	•		•		•	•	•		•	•
UVA & UVB greater than 95% blocking		•	•	•	•	•	•	•	•	•	•	•	•
Swimming pool cover translucent roof sheet			•					•	•	•			
Fire and smoke retardant translucent roof sheeting					•				•	•	•		
Heat reducing & reflecting translucent roof sheeting				•		•			•	•			
Solar Control Translucent roof sheeting				•									
Heavy duty fibreglass roofing and cladding							•		•				
Coloured Translucent Roof sheeting		•	•					•		•	•	•	
Solid Colour GRP roofing and cladding							•		•				
Corrosive resistant translucent roof sheet			•					•	•	•			
Corrosive resistant solid coloured GRP heavy duty roofing and cladding							•		•				
Aesthetically unique translucent sheeting				•						•		•	
10 year warranty*												•	•
15 year warranty*	•												
25 year warranty*					•	•	•						
20/10 year warranty*								•					
25/15 year warranty*		•											
25/20 year warranty*			•	•				•					
Lifetime Platinum warranty - 10 Year Hail										•			
Lifetime warranty - 5 year Hail											•		•

*Refer to the Alsynite Technical catalogue for full warranty information.



TOPGLASS® COLOUR: OPAL PROFILE: MAXISPAN® 2400 G/M²

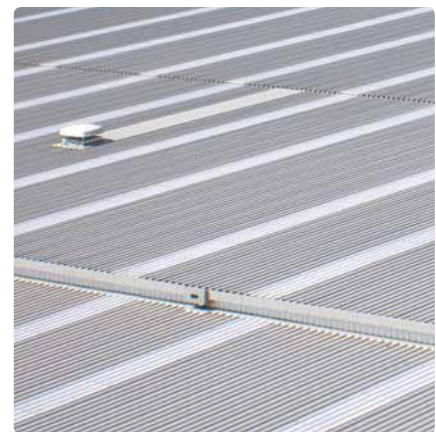

Technical Information



Load Span Capabilities (Based on 1.5kPa distributed uplift load)								Curved roofing minimum drapecurve radius (m)	
Grade	1800g/m ²	2000g/m ²	2400g/m ²	2800g/m ²	3050g/m ²	3660g/m ²	3660g/m ²	1800g/m ²	2200g/m ²
Sheet thickness	1.1mm	1.2mm	1.5mm	1.9mm	2.0mm	2.5mm	Ultra-Safe	1.1mm	1.3mm
Profile (to match)									
Corrugated, Custom Orb	1.000(s)	–	1.250	1.400	1.500	1.600	1.600	3.8	4
5 Rib (Trimdek etc)	1.200(s)	–	1.500	1.600	1.700	2.000	1.800	8	9
Plumbdek, Trimline	1.200(s)	–	1.500	1.600	1.700	2.000	1.800	8	9
MC700, MC750, MC770	1.200(s)	–	1.500	1.600	1.700	2.000	1.800	8	9
Ribline 960	–	–	1.500	1.600	1.700	2.000	1.800	8	9
Hi Five, Six Rib	1.200(s)	–	1.500	1.600	1.700	2.000	1.800	8	9
MC1000, Metric™, Windek™	1.200(s)	–	1.500	1.600	1.700	2.000	1.800	8	9
V Rib™	1200	–	1.500	1.600	1.700	2.000	1.800	12	14
ST7, Silbery7, LT7™, V8, ST900, Multirib, BB900™, MF 900	–	–	1.800	1.950	2.100	2.400	1.800	12	14
Multispan, MC930, Mega 5, Topspan™, Maxispan, SS900, RM900	–	–	2.200	2.400	2.600	3.000	2.500	16	18
Purlindek	1.900(s)	–	2.650	2.900	3.300	3.600	2.500	18	21
Concealed clip Deck Profiles	–	1.200(s)	1.500	1.550	1.700	2.000	1.600	16	18
Supersix	1.150(s)	–	1.500	1.550	1.650	1.950	1.900	16	17

Alsynite NZ Ltd has utilised the NZMRM Test bed facility to test industrial roof profiles in excess of 2.0kPa UDL. Product spanning can be increased by increasing the weight (thickness) of the sheet. Based on 1.5kPa UDL the information contained in the chart is relative to intermediate Purlins, where the sheeting is in single runs and is to be supported by the main roofing and cladding at each side lap. It is important that Purlin spacing be reduced for curved structures, and Alsynite NZ Ltd should be consulted for specific design criteria.

(s) Denotes standard translucent roof sheet weight ex stock. For all other profiles and weights contact Alsynite NZ Ltd.

Profiles

All Topglass® products are available to match common roof profiles, subject to minimum quantity order and raw material availability.

Colour Variation

Due to variations in raw materials shade variations can occur between manufacturing batches.

Weight/Thickness of Sheeting

Alsynite GRP roofing products can be manufactured in varying thicknesses:

Roof profiles: 1800g/m² (1.1mm) – 3660g/m² (2.5mm)

Sheet Lengths

As Topglass® products are manufactured in New Zealand, all roofing profiles can be manufactured to any length.

Design Considerations

Metal roofing profile height is an important design consideration where GRP natural lighting will be installed in conjunction with long lengths of metal roofing. Very low roof pitches (5 degrees or less) combined with low profile metal roofing risk water ingress. Alsynite recommends in this instance roofing profiles with at least a minimum of 32mm should be utilised in these applications.

Please consult Alsynite where wind loads exceed 1.5 kPa (kilopascal) for recommended spanning information.

ROOFING & PROFILES (FIJI) LTD



ALSYNITE NZ LTD

Head Office

7 De Leeuw Place,
Te Rapa Park,
Hamilton 3200
PO Box 10409,
Te Rapa
Hamilton 3241
p 07 850 5088
f 07 850 5003

Distribution Centres:

Palmerston North

74 Malden Street, Roslyn
Palmerston North 4414
PO Box 4643,
Manawatu Mail Centre
Palmerston North 4442
p 06 356 5384
f 06 356 5387

Christchurch

18 Nga Mahi Road,
Sockburn
Christchurch 8042
PO Box 6083
Christchurch 8442
p 03 348 3375
f 03 348 3376

Invercargill

140 Mersey Street
Invercargill 9810
p 03 214 6002
f 03 214 6005